



mod. **CAPRI DELUXE SAP - SED**

Instruction Booklet
Bedienungsanleitung
Livret D'Instructions
Libro De Instrucciones



FOREWORD

This manual is for use by qualified personnel and contains information and tips to use and keep your coffee maker as efficiently as possible. Please read all instructions very carefully before you actually use your machine to make sure the machine works properly and to ensure a long working life. Instructions are part of the product. Please keep this document. This booklet refers to the following models:

Model – CAPRI DELUXE SAP

Semiautomatic with continuous dispensing and solenoid valve controlled by rocker switch located on the control panel. Available in **1, 2 group versions**.

Model – CAPRI DELUXE SED

Microprocessor-controlled electronic model with programmable dosing through a keypad with indicator lights. Available in **1, 2 group versions**.

SPECIFICATIONS

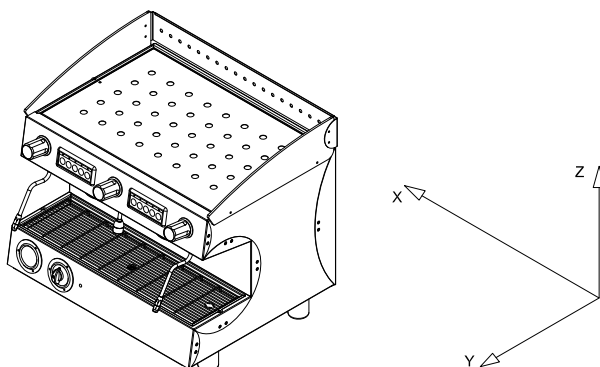

		GROUPS	
		1	2
Width (X)	mm	430	600
Depth (Y)	mm	485	485
Height (Z)	mm	535	535
Capacity	litres	4,5	10
Net weight	Kg	38	49
Gross weight	Kg	41	53
Voltage	V	120/230/400	120/230/400
Heating element input	kW	1,95/2,4	2,7/4,5
Electric pump input	kW	0,15	0,15
Power absorbed by the external electric pump	kW	0,15	0,15
Solenoid valve input	kW	0,0135	0,0225
Automatic level controller input	kW	0,01	0,01
Boiler design pressure	(2 Bar) MPa	0,2	0,2
Boiler working pressure	(0,8-1 Bar) MPa	0,08:0,1	0,08:0,1
Safety valve calibration pressure	(1,8 Bar) MPa	0,18	0,18
Exchanger design pressure	(20 Bar) MPa	2	2
Exchanger safety valve calibration pressure	(12 Bar) MPa	1,2	1,2
Mains water pressure (max)	(6 Bar) MPa	0,6	0,6
Coffee dispensing pressure	(8-9 Bar) MPa	0,8/0,9	0,8/0,9

The weighted sound pressure level A of the coffee machine is less than 70dB.

For correct appliance operation and trouble-free maintenance, please read this booklet carefully and comply with the instructions and rules, also referring to the diagrams given in it.

INSTALLATION

Before installing the appliance ensure that the mains voltage and power correspond to the data given in the specifications table. Take the appliance out of the packaging and put it in its final place of installation ensuring that it is stable and safe and that there is the necessary space for using it.

Place the machine in a way that the distance between the grid and the floor is wider than 1,5 mt. To clean the internal circuit more efficiently, you are recommended to empty and fill the boiler a number of times and deliver simple water and coffee to be thrown away.

ELECTRICAL CONNECTION

Before connecting the power cable, follow the instructions below to install a safety switch and of the proper capacity:
 Install ground cable, then phase cables. Uninstall phase cables first and then ground if needed.
 Make sure the ground connection complies with existing standards and regulations.
 N.B. CHECK THAT THE DATA ON THE RATING PLATE CORRESPOND TO YOUR MAINS ELECTRICITY SUPPLY.

INSTALLING THE POWER SUPPLY CABLE

Connection of the resistance

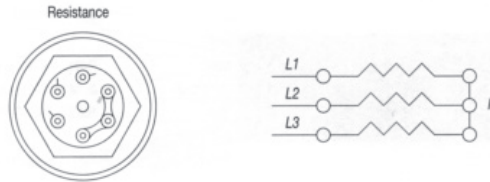

Electrical feeding variance

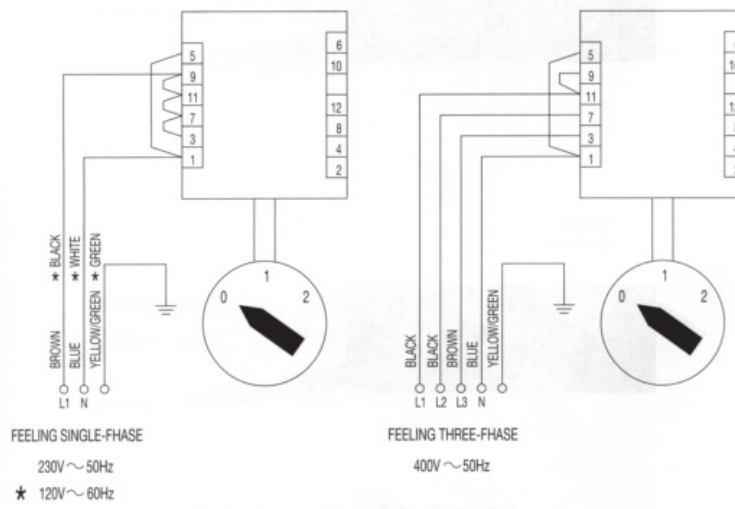

400 VOLTS
THREE-PHASE + NEUTRAL

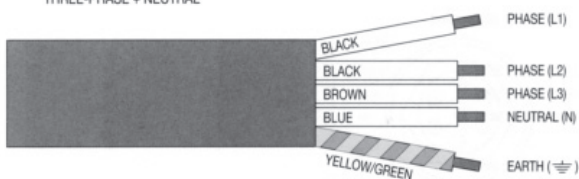

230 VOLTS
SINGLE-PHASE

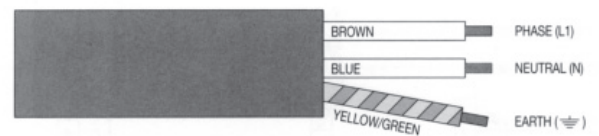

120 VOLTS
SINGLE-PHASE

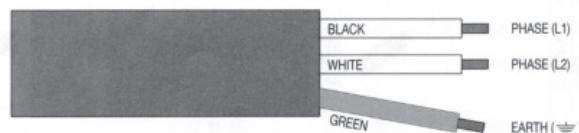

Feeding cable installation diagram

Water connection

- 1) Only cold water must be supplied to the appliances.
- 2) If the mains water pressure exceeds 6 bar, a pressure reducer must be installed to regulate the outlet pressure to a maximum of 6 bar.
- 3) Connect the drain hose to the tray, avoiding sharp bends and keeping a sufficient slope for regular flow of the drain water.
- 4) Connect the 3/8" hose to the mains outlet and then to the water softener and to the appliance.

N.B. A water softener is indispensable for correct appliance operation, best coffee in the cup and long life of the components, since it removes scale and residues from the water that would otherwise shorten their life.

The company is relieved of all and any liability in the event of failure to comply with the above instructions.

Open the tap and let water flow through the deconcentrator to clear dirt off the circuit before plugging the hose into the pump.

USE

Preliminary check

Before using the appliance, check that:

- the plug is inserted properly into the mains power outlet;
- the water filling hose is correctly connected to the mains water outlet, check for leaks and that the water tap is open;
- the drain pipe is positioned in accordance with the preceding instructions.

With a steam tap (B) open, put the on/off switch (D) to position 1 and wait for the water in the boiler to reach the maximum level set by the electronic control. If the boiler does not fill within the set time-out (90 sec.), the pump stops and the indicator lights on the keypad start to blink. In this case put the on/off switch (D) to position 0 and then to position 1 to finish filling the boiler.

Now put the on/off switch (D) to position 2 so that the heating elements are powered and therefore start to heat the water.

Wait for steam to come out the steam nozzle (B), then close the tap and, using the Boiler pressure gauge, check that the pressure has reached and maintains a value of 0.8:1 bar. If it is not on this value, turn the adjusting screw on the pressure switch (+ increase, - decrease, see figure below).

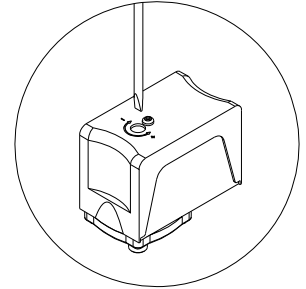

Hot water

Ensure that the boiler pressure gauge indicates a pressure of 0.5:1 bar. Turn the tap knob (C) counter-clockwise.

Pay the utmost attention in order to prevent scald burns.

Steam

Except for the 1-group machine that has just one steam nozzle, all the other models have 2 located at the sides. These steam nozzles are recessed but can swivel out thanks to an articulated joint. To dispense steam, just turn the knobs (B) counter-clockwise.

Pay the utmost attention in order to prevent scald burns.

Coffee with Mod. CAPRI DELUXE SAP

Insert the filter holder (E) into the group head (F) turning the filter holder counter-clockwise. Press button (I), wait for the required quantity of coffee to be dispensed and then put it back to its original position.

Coffee with Mod. CAPRI LUXE SED

Insert the filter holder (E) into the group head (F) turning the filter holder counter-clockwise. Select the type of dispensing required on the keypad (M):

M1=One strong/normal coffee.

M2=One normal/weak coffee.

M3=Two strong/normal coffees.

M4=Two normal/weak coffees.

M5=Electronic programming key or continuous manual dispensing.

Dispenser programming

- a) To access this phase keep the button M5 on the first pushbutton panel on the left pressed for over 5 seconds. The indicator lights of the buttons M5 start to blink continuously. Select the caption corresponding to the amount required and press to dispense. The indicator light of button M5 and that of the selected caption remain lit. When the required amount has been dispensed, press the selected dispensing button again so that the control unit stores the data. Repeat the above procedure for all 4 dispensing buttons on the pushbutton panel. A dispensed quantity may also be set for the hot water button (M6) by repeating the above procedure. Upon completion of the procedure, the remaining groups will automatically use the stored quantity. The other groups may, however, be programmed independently by repeating the same procedure as above after having programmed the first group on the left.
- b) There are 2 safety systems inside the control unit designed to protect the electronic system and the various parts of the appliance. If, upon pressing a dispensing button, the corresponding indicator light starts blinking, this indicates a malfunction in the electronic system or lack of water. For safety reasons, the dispensing of water stops after 4 minutes and in any case after 4 litres of water.
- c) The CAPRI XLC SED electronics also offers the possibility of reproducing the pre-brewing effect by wetting the coffee for 0.6 seconds and then stopping the subsequent brewing from starting for 1.2 seconds. This option is only applicable for single shots of coffee.

To enable pre-brewing

With the appliance switched off, put the on/off switch (D) to position 1 and at the same time keep the button (M1) on the left-hand group pressed until the indicator light corresponding to the button (M5) remains lit; then release the button (M1). Now put the on/off switch (D) to position 0 and then to position 2 in order to store the operation.

To disable pre-brewing

With the appliance switched off, put the on/off switch (D) to position 1 and at the same time keep the button (M2) on the left-hand group pressed until the indicator light corresponding to the button (M5) remains lit; then release the button (M2). Now switch the appliance off and then on again using the on/off switch (D) in order to store the operation.

CLEANING

Filter: after having dispensed the last cup of coffee, the filter and filter holder must be washed with water. If they are damaged, worn or clogged, they should be replaced.

Drip tray and grid: the drip tray and grid should be removed frequently and coffee residues cleaned away.

Water softener: the softener should be periodically regenerated according to the manufacturer's directions given in the instruction booklet.

External housing: the external housing and the steel parts should be cleaned with sponges and soft cloths to avoid scratching. Only use detergents that do not contain abrasive powders or solvents and do not use steel wool.

WARNINGS: when using the appliance it is recommended that the various instruments be kept under control, checking that they are in the previously indicated normal working conditions.

When the appliance has been left unused for a number of days, or every 2/3 months during normal use, to clean the internal circuits more efficiently, it is good practice to fill the boiler a number of times and deliver simple water and coffee to be thrown away.

APPLIANCE FAILURE

The user must check that this is not due to:

- power failure or blackout.
- lack of mains water supply or no water inside the boiler.

For any other causes, contact a qualified SANREMO After-Sales Service Centre.

BEFORE CARRYING OUT ANY WORK INSIDE THE APPLIANCE OR REMOVING ANY PART OF THE HOUSING, ALWAYS DISCONNECT FROM THE ELECTRICITY SUPPLY.

WARRANTY

Every purchased appliance (keep the receipt, invoice and delivery note) is covered by a statutory guarantee. This warranty envisages the replacement free of charge of parts that are shown to the service centre or manufacturer's satisfaction to be defective due to faulty materials or workmanship and providing that the appliance has not been misused or tampered with by unauthorised persons or persons using incorrect components or techniques.

Any defective part shall be returned to the manufacturer.

NOTE: never activate the pump without water. Excessive heat will damage the pump and **no warranty replacement is granted in that case.**

WARNINGS

The appliance must not be cleaned using a water jet.

Do not put the appliance in water.

The appliance must not be positioned near to any source of heat.

The appliance is unsuitable for outdoor installation.

To ensure safe use the appliance must be in a level position.

If the power cable is damaged, have it replaced by a SANREMO After-Sales Service Centre, since a special tool is required for this purpose.

The appliance must be used in rooms with a temperature between 5°C and 35°C.

IN THE EVENT OF FAILURE OR MALFUNCTION, REQUEST SERVICE ONLY FROM QUALIFIED PERSONNEL AT THE AFTER-SALES SERVICE CENTRE.

The data and features indicated in this booklet are not binding on the manufacturer, which reserves the right to make changes to its models at any time. The manufacturer shall not be under any liability for injury to persons or damage to property arising from failure to comply with the instructions given in this booklet.

INFORMATION FOR USERS

In accordance with article 13 of legislative decree no. 151 "Implementation of directives 2002/95/EC, 2002/96/EC and 2003/108/EC on restriction of the use of certain hazardous substances in electrical and electronic equipment and the disposal of waste". The appliance or packaging is marked with the symbol of a bin with a cross to indicate that at the end of its working life it must be disposed of separately from other waste.



Separate collection of this appliance at the end of its working life is organised and managed by the manufacturer.

The user wanting to dispose of this appliance should therefore contact the manufacturer and follow the separate waste collection system to dispose of the appliance at the end of its working life.

Appropriate separate collection and the subsequent recycling, treatment and ecological disposal of the disused appliance help avoid possible negative effects on the environment and health and encourage the re-use and/or recycling of the constituent materials.

The unlawful disposal of the product by the user is punishable by the administrative sanctions provided for by the legislation in force at the time.

External pump connection instructions

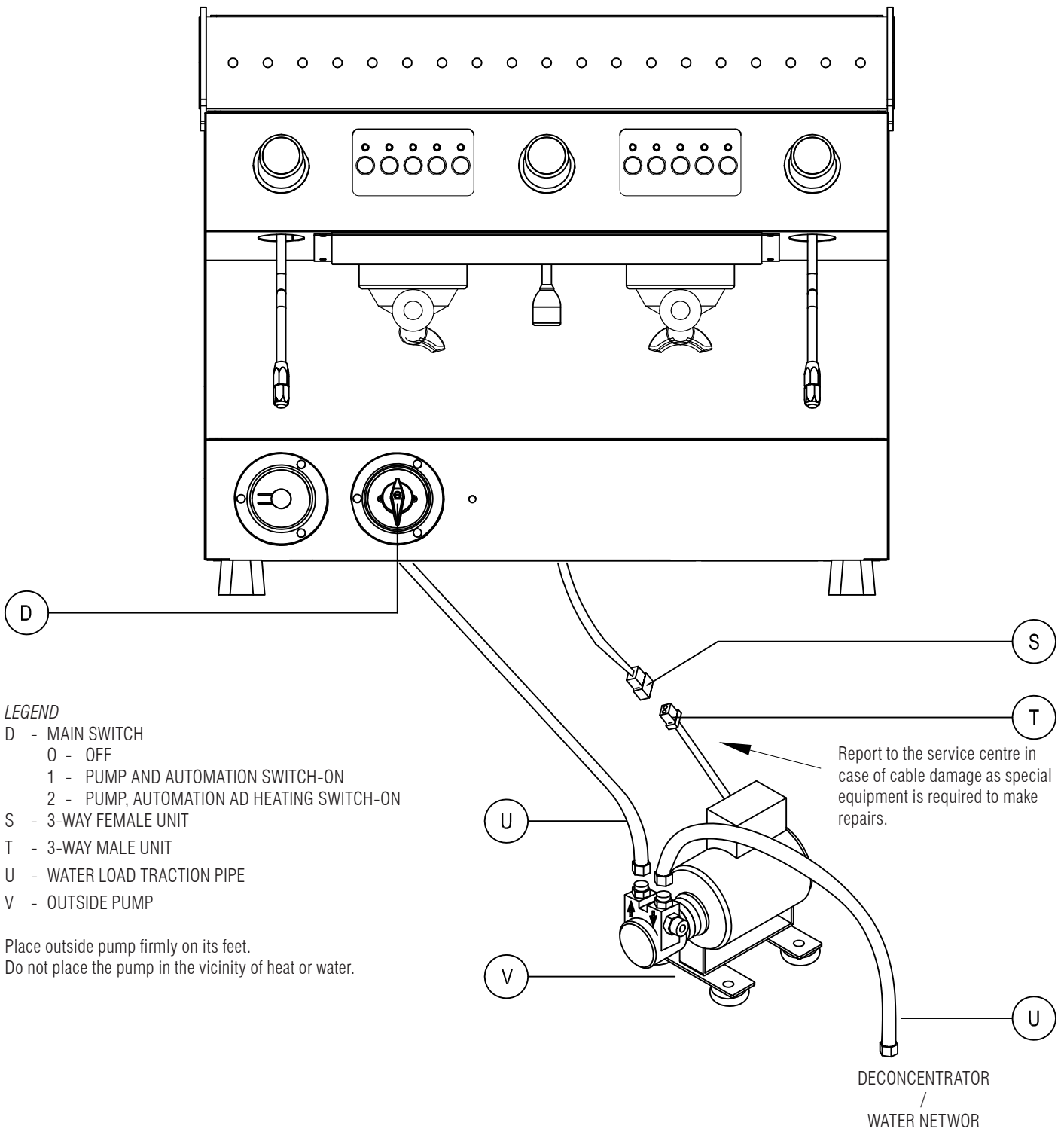

Warning – correct use of rotary pumps

1-Proper Alignment of Pump and Motor

On occasion the noise of a motor-pump assembly is caused by a poor alignment.

When the coupling between motor and pump is rigid, the pump rotor and the motor rotor may be out of axis. If this condition is maintained over time the most likely damage is seizure of the pump.

An efficient solution of this problem is the use of an elastic coupling between pump and motor. Fluid-o Tech supplies an optional kit code N. 10051020.

2-Quality of Water.

Tight mechanical tolerances of components and materials used for rotary vane pumps require a very clean water, free from suspended particles. Sand, deposits on connecting pipes or the resins of the sweetener, when flowing through the pump, may scratch graphite parts causing problems of insufficient pressure and flow rate.

If a closed loop hydraulic circuit is not available to guarantee a clean water and no sources of contamination Fluid-o-Tech recommend to install a 5-10 micron filter between the sweetener and the pump.

Recommended filter: food approved polipropilene wire cartridge.

Keep the filter clean.: an upstream dirty filter will create cavitation and the pump will break shortly (see section 4).

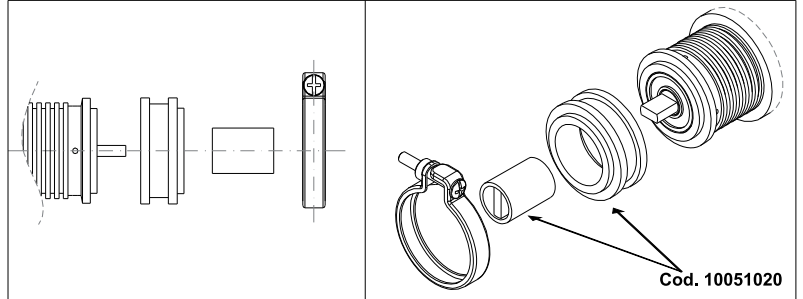

3-Dry operation

Rotary vane pumps may operate in dry condition only for a very short time- few seconds!

Without a proper water cooling the temperature of the mechanical seal will increase very quickly with resulting breakage. The most likely impact is a remarkable leak visible from the four drain holes close to the motor clamp. For potential lack of feed from city water line Fluid-o-Tech recommend the installation of a minimum pressure safety switch upstream from the pump.

In case of feed from a tank install on the tank a minimum level switch.

4-Cavitation

Cavitation shows when feed flow rate does not match the pump design requirement: most frequent causes are dirty filters, small diameter pipes, more users on the same line.

Opening of the safety valve (generally installed upstream from pump and filter) must happen

before the pump start up. This will avoid cavitation. For the same reason closing of the safety valve must be delayed after the pump shut down.

The most noticeable effect is an increase of noise. If cavitation continues the impact is the same as of dry operation.

5-Back Feed of Hot Water

If a non return valve between the pump and the hot water vessel is defective the pump may come in contact with hot water(90-100°C). Dimensional variations of components will cause seizure of the pump.

6) Wrong connections

Pumps connectors are 3/8" NPT(conical) or 3/8" GAS(cylindrical).

Connectors with thread different from the recommended type are occasionally used. Sealing is made with a glue or with teflon tape. If the connector is forced it is possible to create beards; if excess sealing glue is used the extra quantity of glue may enter into the pump body.

In both cases it is likely to create a damage.

7) Pressure strokes

To avoid pressure strokes opening of solenoid valves installed downstream must happen before the start of the pump. For the same reason closing of the valve must be delayed after stopping of the pump.

A pressure stroke may break graphite parts and damage mechanical seal causing blockage of the pump and leaks.

8) Handling

A crash on the floor may create deformations that will jeopardize the tight mechanical tolerances of the pump components. For the same reason be very careful when clamping the pump to mount or demount connectors.

9) Scale build up

Scale deposits will quickly show on inner components when using hard water, not sweetened with ion exchange resins.

Scale formation increases when the pressure relief valve is used as flow rate regulator: the rate of scale deposition increases with increasing of closed loop circulation.

Scale deposits cause an increase of torque, occasional seizure of the pump or a reduction of operating pressure because the pressure relief valve cannot work properly.

To minimize this problem Fluid-o-Tech suggest to use pumps with flow rate matching the hydraulic circuit features.

In some circuits it is advisable to periodically remove scale with a chemical treatment.

Mod. CAPRI 2GR SAP

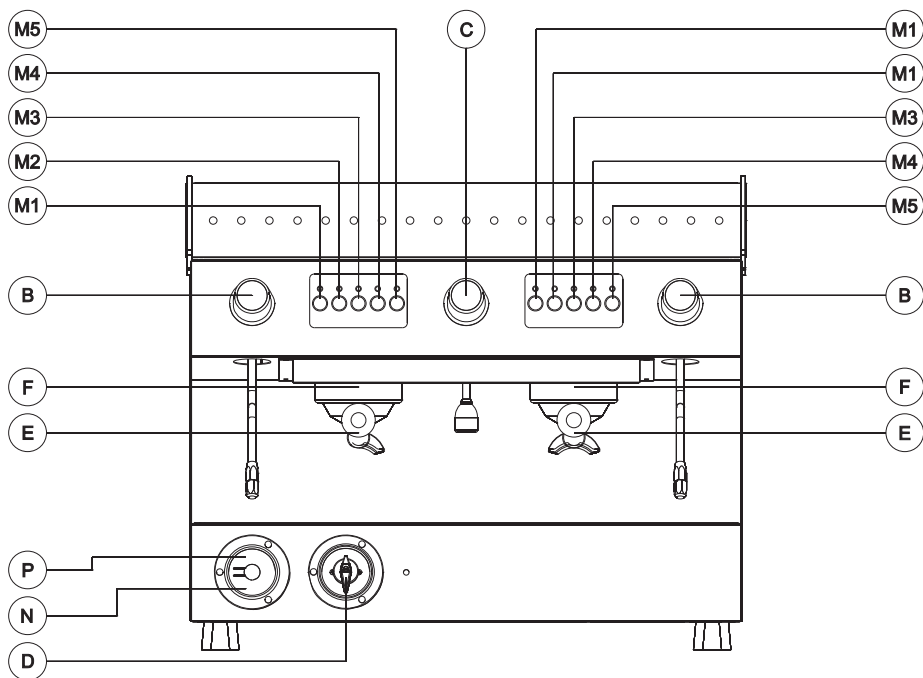

Mod. CAPRI 2GR SED

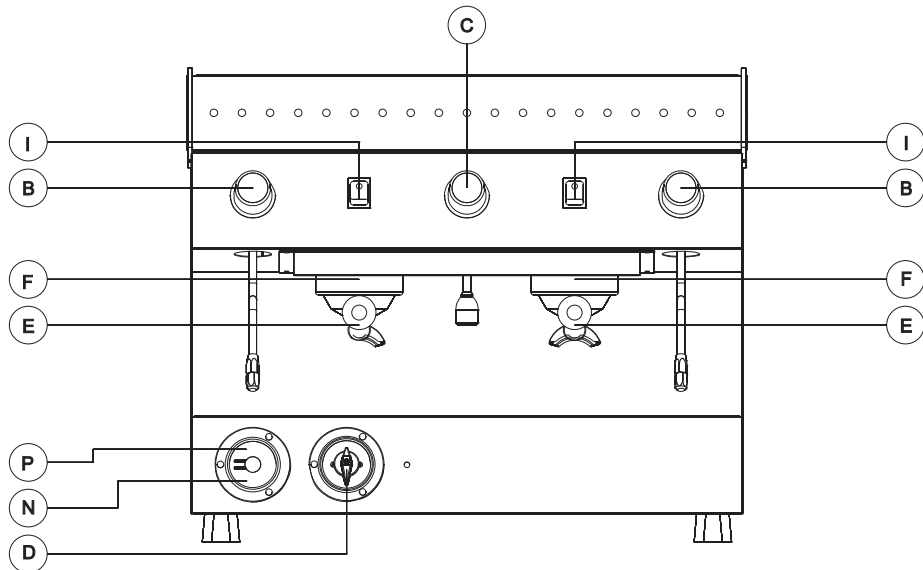

PARTS

B - Steam tap knob

C - Water tap knob

D - On/off switch

O - Off

1 - Pump and automatism on

2 - Pump, automatism and electric heating on

E - Filter-holder

F - Filter-holder head unit

I - Dispense stop button

M1 - Dispense one short shot of coffee

M2 - Dispense one long shot of coffee

M3 - Dispense two short shots of coffee

M4 - Dispense two long shots of coffee

M5 - Continuous dispensing and programming key

M - Pump pressure gauge

P - Boiler pressure gauge

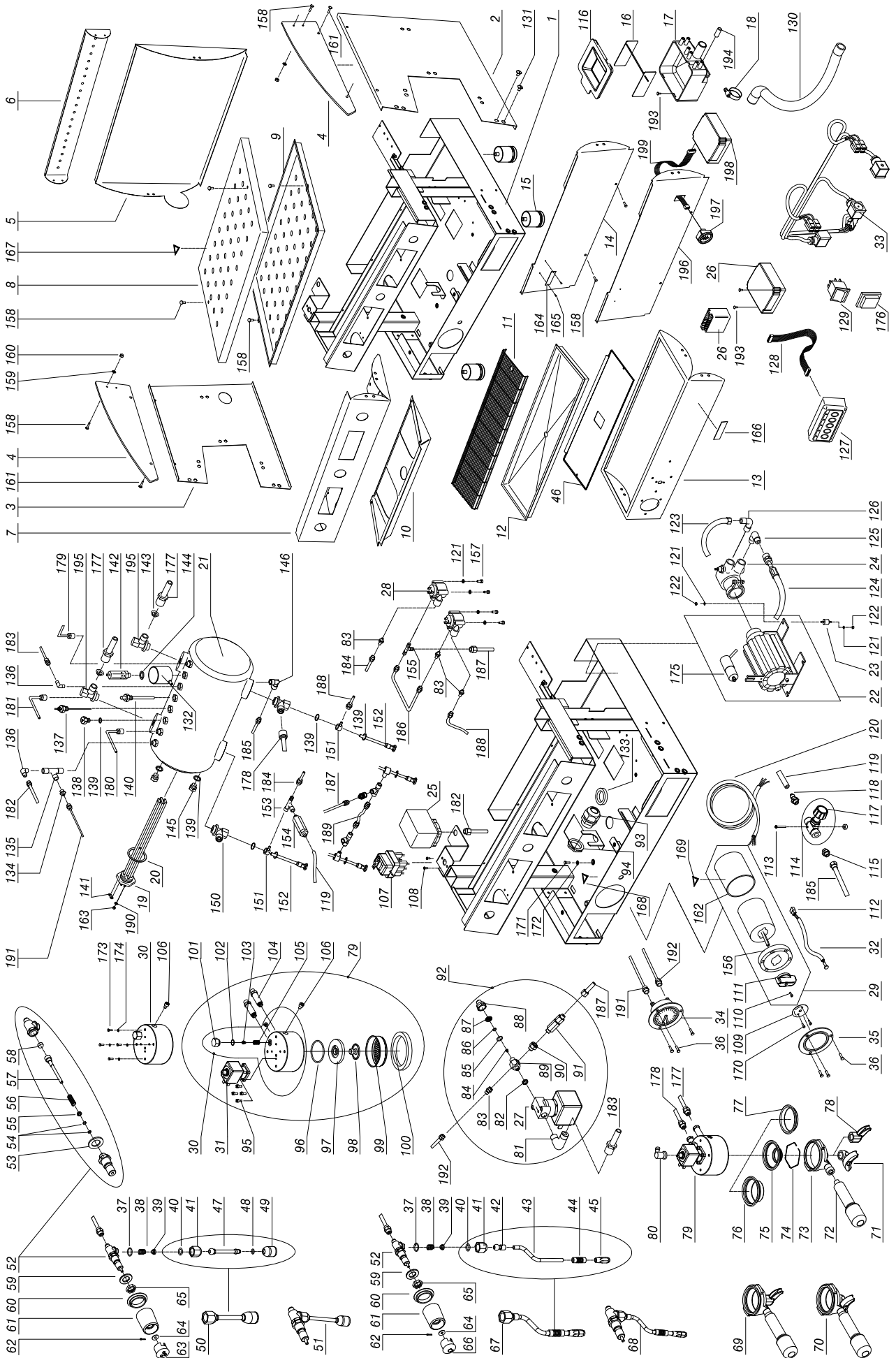

Exploded view CAPRI DELUXE update 02-09

PARTS OF EXPLODED VIEW CAPRI DELUXE UPDATE 02-09

POS.	CODE	DESCRIPTION
1A	10022828	FRAME CA 1GR XLC-XLE-DLX BLACK
1B	10022834	FRAME CA 2GR DLX BLACK
2A	10022765	R.H. SIDE PANEL CA BLUE
2B	10022766	R.H. SIDE PANEL CA BLACK
2C	10022802	R.H. SIDE PANEL CA RED
2D	10022814	R.H. SIDE PANEL CA WHITE
3A	10022768	L.H. SIDE PANEL CA BLUE
3B	10022769	L.H. SIDE PANEL CA BLACK
3C	10022803	L.H. SIDE PANEL CA RED
3D	10022816	L.H. SIDE PANEL CA WHITE
4	10352031A	R.H./L.H. CUP GUARD CA
5A	10022760B	SS REAR PANEL CA 2GR
5B	10022786B	SS REAR PANEL CA 1GR
6A	10022778	REAR CUP GUARD BLACK CA 2GR
6B	10022779	REAR CUP GUARD BLUE CA 2GR
6C	10022795	REAR CUP GUARD. BLUE CA 1GR
6D	10022807	REAR CUP GUARD RED CA 2GR
6E	10022809	REAR CUP GUARD BLACK CA 1GR
6F	10022811	REAR CUP GUARD RED CA 1GR
6G	10022818	REAR CUP GUARD WHITE CA 1GR
6H	10022812	REAR CUP GUARD WHITE CA 2GR
7A	10022772	UPPER FRONT PANEL CA 2GR SED
7B	10022774	UPPER FRONT PANEL CA 2GR SAP
7C	10022791	UPPER FRONT PANEL CA 1GR SED
7D	10029773	UPPER FRONT PANEL CA 1GR SAP
8A	10015442	UPPER GRID CA 2GR XLC
8B	10015444	UPPER GRID CA 1GR XLC
9A	10015440	UPPER DRIP TRAY CA 2GR XLC
9B	10015446	UPPER DRIP TRAY CA 1GR XLC
10A	10022758A	LOW GROUP HEAD PROTECTION CA 1GR
10B	10015312A	LOW GROUP HEAD PROTECTION CA 2GR
11A	10015532	DRAIN GRID CA 1GR FILINOX
11B	10015534	DRAIN GRID CA 2GR XLC FILINOX
12A	10015830	DRAIN PLATE CA 2GR XLC
12B	10015836	DRAIN PLATE CA 1GR XLC
13A	10015834	BOTT. FRONT PANEL CA DLX 2GR PRINTED
13B	10015838	BOTT. FRONT PANEL CA DLX 1GR PRINTED
14A	10022764	FRONT PROTECTION CA 2GR
14B	10022821	FRONT PROTECTION CA 1GR
15	10352065	TELESCOPIC FOOT D50X55 INOX
16	10012144	FLOW REGULATOR FOR DRIP TRAY
17	10022474	UNIVERSAL DRIP TRAY
18	10806099	SS HOSE CLAMP
19A	10455050	RESISTOR 1950W 230V 1GR
19B	10455051	RESISTOR1950W 120V 1GR
19C	10455052	RESISTOR2700W 230V 2GR
19D	10455053	RESISTOR 2700W 120V 2GR
19E	10455060	RESISTOR 2400W 230V 1GR
19F	10455065	RESISTOR 2400W 120V 1GR
19G	10455080	HEAT. ELEM 4500W 230V 2GR
20	10502020	PTFE WASHER D56X41X2mm
21A	10002635B	COPPER BOILER 1GR D.180
21B	10002670	COPPER BOILER 2GR 10 LITRES D.190
22A	10252079A	EL. MOTOR150W 120V W/CONNECTOR
22B	10252080A	EL. MOTOR 150W 230V W/CONNECTOR
23	10255022	VIBRATION DAMPING BUFFER
24	10252070A	ROTARY PUMP 150L/H W/CLAMP
25	10602010A	PRESSURE SWITCH
26A	10112010A	LEVEL CONTROL SAP 230V
26B	10112011	LEVEL CONTROL SAP 120V
26C	10112012	CONTROL UNIT XLC SED 120V

POS.	CODE	DESCRIPTION
26D	10112072B	CONTROL UNIT XLC SED 230V
27A	10303088	2-WAY SOL. V. 230V 0-10B
27B	10303090	2-WAY SOL. V.120V 0-10B
28	10112134	VOLUMETRIC METER 1/8"
29A	10122036A	SINGLE-PHASE JUMPER SWITCH
29B	10122038A	THREE-PHASE JUMPER SWITCH
30	10052028	SPOUT ASSEMBLY RING W/FILTER DISK AND GASKET E61
31A	10302066	LOW 3-WAY SOL. V. 32X32 230V
31B	10305555	LOW 3-WAY SOL. V. 32X32 120V
32A	10553021	ORANGE IND. LIGHT D6 230V WIRED
32B	10553024	ORANGE IND. LIGHT D6 120V WIRED
33A	10102155	WIRING CA 2GR SAP
33B	10109103B	WIRING CA 1GR SED XLC
33C	10109104B	WIRING CA 2GR SED XLC
33D	10109110A	WIRING CA 1GR SAP
34	10552021A	PRESSURE GAUGE
35	10552022A	FLANGE FOR SELECT. SWITCH
36	10805069	SCREW (HEX.CONV.SO) M3X10 A2
37	10402056	O RING 2062 VITON
38	10402043	ARTIC. JOINT SPRING
39	10402054	ARTIC. JOINT CAP
40	10402063	O RING 115 EPDM
41	10402022B	ARTIC. JOINT NUT
42	10858589	ARTICULATED JOINT
43	10422136A	STEAM NOZZLE CAPRI
44	10753050	ANTI-SCALD RUBBER PROTECTION
45	10402202	INOX NOZZLE JET 4 HOLES 12x35
46A	10015448	CONTROL UNIT PROT. PLATE, CA 2 XLC
46B	10015482	CONTROL UNIT PROT. PLATE, CA 1 XLC
47	10022140	WATER DISPENSING TUBE
48	10502041	O RING 2025 EPDM
49	10402140	DISPENSING HEAD
50	10402145	COMPLETE WATER NOZZLE CA
51	10402010	COMPLETE WATER TAP CA
52	10402120A	TAP BODY
53	10505561	TAP COPPER BUSHING
54	10505121	O RING NBR TAP ROD
55	10402015	TAP ROD BUSHING
56	10402014	TAP ROD SPRING
57	10402061	CENTRAL TAP ROD
58	10505558	TAP ROD SEAL
59	10803547	PLAIN WASHER D20 ZN
60	10402070	KNOB RING NUT
61	10402074	TAP KNOB
62	10806370B	TAP SPLIT PIN
63	10351115	WATER TAP KNOB CAP PRINTED
64	10402040	TAP BRASS WASHER
65	10402028	CHROMED RAISED HALF NUT 1/2"
66	10351114	STEAM TAP KNOB CAP PRINTED
67	10402260	COMPLETE STEAM NOZZLE CA
68	10402230	COMPLETE STEAM TAP CA
69	10402121A	1-CUP FILTER HOLDER ASSY
70	10402122A	2-CUP FILTER HOLDER ASSY
71A	10052088	SMALL 2-WAY SPOUT, OPEN
71B	10052090	2-WAY SPOUT
72	10052040	FILTER-HOLDER HANDLE
73	10052030	FILTER-HOLDER BODY
74	10052050	FILTER RETAINING SPRING
75	10052100	1-CUP FILTER
76	10052110	2-CUP FILTER
77	10052220	SOLID FILTER

POS.	CODE	DESCRIPTION
78A	10052078	SMALL 1-WAY SPOUT, OPEN
78B	10052080	1-WAY SPOUT, OPEN
79A	10052206A	RING ASSY. CA GDE61 230V
79B	10052208A	RING ASSY. CA GDE61 120V
80	10255028A	SWIVEL ELBOW F1/8
81	10852030A	1020 6-1/8" M ELBOW
82	10853085	HEX NUT 1/8"
83	10852080A	1050 6-1/8" M STRAIGHT COUPLER
84	10052144	FILLING BLOCK JET HOLE D.1.5
85	10402063	O RING 115 EPDM
86	10502028	O RING 3037 VITON
87	10052139A	SS MESH FILTER
88	10852672	STRAIGHT REDUCER NI CH22X23 3/8F-1/4M
89	10852682	CONNECTOR NI CH.22X38 1/8" MFM
90	10852901	2520 1/8"F-1/4" M STRAIGHT REDUCER
91	10652020B	NON-RETURN VALVE SHORT
92A	10056061A	FILL ASSY. 230V AC VALVE MODEL
92B	10056062A	FILL ASSY. 120V AC VALVE MODEL
93	10102250	CABLE GLAND PG 21
94	10102249	CHECK NUT PG.21
95	10805071	SCREW (HEX.CH.SOCK.) M4X10 A2
96	10502070A	OR 3187 EPDM FDA
97	10052248	MAZZOCCO RING ASSY. X GASKET AND FILTER DISK E61
98	10052141	DIFFUSER GR. E61
99	10052120	MESH FILTER DISK ASSY. E61
100	10502110	UNDERCUP GASKET ASSY. E61
101	10052142	RING GROUP HEAD JET CLOSING CAP
102	10052143	RING GROUP UPPER CAP GASKET
103	10052135	GROUP HEAD JET HOLE D.O.8
104	10852033	EXTENSION NI CA RING GROUP HEAD
105	10052136	GROUP HEAD FILTER E-61/RING
106	10805078	SCREW (HEX CH SOCK) M6X8 A2
107	10111015	THERMOSTAT W/ MANUAL RESET
108	10805872	CHEESEHEAD SCREW + M4X6 ZN
109	50302018	SELECTOR SWITCH LABEL SER.012
110	10122011	SWITCH KNOB SCREW
111	10122015	SWITCH KNOB
112	10105190	2-WAY BLOCK F.
113	10803010	CHEESEHEAD SCREW - M4X40 ZN
114	10402059	DRAIN TAP W/KNOB
115	10852050A	1050 8-1/8" M STRAIGHT COUPLING
116	10852050A	1050 8-1/8" M STRAIGHT COUPLING
117	10402060	BOILER DRAIN TAP KNOB
118	10853058	1510 STRAIGHT OUTLET CONNECTOR 6-1/8" M
119	10905010	TRANSP. SILICONE TUBE
120A	10102190	POWER CABLE 3X2.5 M3 N5 SINGLE-PHASE
120B	10102191	POWER CABLE 5X2.5 M3 N4 THREE-PHASE
120C	10102193	POWER CABLE 3X4 M3 N7
120D	10102196	POWER CABLE 3x12AWG SJOOW 3MT
120E	10102197	POWER CABLE 3x14AWG SJOOW
121	10803519	SERRATED WASHER D4.2.ZN
122	10805512	MEDIUM-HEIGHT NUT 4MA ZN
123	10852450	STAY PIPE L=2000
124	10852470	STAY PIPE L=450
125	10852530A	1020 10-3/8" M ELBOW
126	10852280A	1020 8-3/8" M ELBOW
127	10112066A	PUSHBUTTON STRIP FOR DISP.3D5
128A	10112078	PIN TO PIN CABLE 600mm
128B	10112079	PIN TO PIN CABLE 800mm
129	10555060A	COFFEE SWITCH W/SCREEN PRINT
130	10852460	HELICALLY WOUND DRAIN PIPE L.2 M

POS.	CODE	DESCRIPTION
131	10805028	TRUSS HEAD SCREW - M6X10 A2
132	10022480	DRIP TRAY SAFETY VALVE
133	10105030	BLACK RUBBER GROMMET
134	10852580A	1050 6-1/4" M STRAIGHT COUPLING
135	10855031	2003 TEE F/F/F 1/4"
136	10852250A	1020 6-1/4" M ELBOW
137A	10112042	LEVEL SENSOR 140mm CA 2GR
137B	10112064	LEVEL SENSOR 120mm CA 1GR
138	10652040	BOILER RELIEF VALVE
139	10852180	COPPER WASHER 1/4"
140	10853053	STRAIGHT SUCTION PIPE 1/4" M
141	10106060	BRASS RESISTOR CONNECTION JUMPER
142	10652012	SAFETY VALVE
143A	10052174	JET HOLE D2.5
143B	10052176	JET HOLE D3
143C	10052178	JET HOLE D3.5
144	10806324	COPPER WASHER 3/8"
145	10852540	2611 1/4" M PLUG
146	10852060A	1020 8-1/4" M ELBOW
147	10855030	2070 TEE M/F/F 3/8" +
148	10852290A	1050 10-3/8" M STRAIGHT COUPLING
149	10852092	2530 STRAIGHT REDUCER 3/8M-1/4F
150	10853228	BOTT. H.EXCHANGER UNION 1/4"-3/8"-3/8"
151	10852240A	1170 6-1/4" JOINT CONNECTION
152	10042040	INJECTOR PTFE D.8
153	10853215	TEE 1/8 M/F/F
154	10655557	EXPANSION VALVE
155	10852028A	1010 6-6-1/8" M TEE
156	10122024	SWITCH METAL FLANGE
157	10805074	HEX-HEAD SCREW M4X8 ZN
158	10805027	TRUSS HEAD SCREW - M4X10 A2
159	10803546	PLAIN WASHER D4 A2
160	10805584	CAP NUT 4MA A2
161	10805018	TRUSS HEAD SCREW - M4X12 A2
162	10122030	SWITCH CASING
163	10806050	NUT M4 X RESISTOR
164A	10952051A	AL RATING PLATE SAN REMO 230V
164B	10952052A	AL RATING PLATE SAN REMO 400V
164C	10952053A	AL RATING PLATE SAN REMO 120V
165	10805950	TEAR-OFF RIVET D3x6
166A	10955018	SAN REMO LABEL 70X11.3
166B	10955020	SAN REMO LABEL 101X16.5
167	10955013	HOT SURFACE TRIANG. LABEL
168	10955025	EARTH TRIANG. LABEL
169	10955015	VOLTAGE TRIANG. LABEL
170	10809019	BURNISHED SCREW (HEX CONV SOCK) M3X8
171	10805105	HEX-HEAD SCREW M6X12 ZN
172	10803536	SERRATED WASHER D6.2 ZN
173	10805075	HEX-HEAD SCREW M5X8 ZN
174	10803520	SERRATED WASHER D5.3 ZN
175	10252038	MOTOR CAPACITOR 150W
176	10105243A	TRANSPARENT SWITCH CAP
177A	10003060	TOP H.EXCHANGER TUBE CA 1 DLX
177B	10003050	TOP H.EXCHANGER TUBE CA 2 DLX
178A	10003062	BOTT. H.EXCHANGER TUBE CA 1 DLX
178B	10003052	BOTT. H.EXCHANGER TUBE CA 2 DLX
179A	10002124A	STEAM TUBE RH CA 1 XLC
179B	10002055A	STEAM TUBE RH CA 2 XLC
180	10002052	STEAM TUBE LH CA 2
181A	10002126	HOT WATER RUN-OFF TUBE CA 1
181B	10002054	HOT WATER RUN-OFF TUBE CA 2

POS.	CODE	DESCRIPTION
182A	10002264	PRESSURE SWITCH TUBE CA1 XLC
182B	10003054	PRESSURE SWITCH TUBE CA 2 DLX
182B	10002262	PRESSURE SWITCH TUBE CA 2 XLC
183A	10002258	BOILER FILL HOSE CA 1 XLC
183B	10002260	BOILER FILL HOSE CA 2 XLC
184A	10003056	SUPPLY HOSE GR. 1 CA 2 DLX SED
184B	10002128	SUPPLY HOSE GR. 1 CA 1 SED
185A	10002236	BOILER DRAIN HOSE CA 1
185B	10002196	BOILER DRAIN HOSE CA 2
186	10002060	CONNECTION TUBE VOLUM. MEAS. 1-2 CA 2 SED
187A	10002633	VOLUM. MEAS. SUPPLY HOSE CA1-2 SED
187B	10002150	SUPPLY HOSE GR CA 1 SAP
187C	10002151	SUPPLY HOSE GR CA 2 SAP
188	10003058	SUPPLY HOSE GR. 2 CA 2 DLX SED
189	10002062A	CONNECTION TUBE GR. 1-2 CA 2 SAP
190	10809024	WASHER D.4.3 COPPER
191	10002030	BOILER PRESS. SW. CAPILLARY TUBE CA 1-2 XLC
192	10002024	PUMP PRESS. SW. CAPILLARY TUBE CA 1-2 XLC
193	10805084	SCREW TC+ M4X10 ZN
194	10052064	DRIP TRAY CAP
195	10853226	TOP H.EXCHANGER UNION 3/8"-3/8"
196	10022744	FRONT PROT. CA 2GR W/LEV. VIEW WIN.
197	10112206	LEV. VIEW WIN. D40
198	10112204	CONTROL UNIT XLC SED 1-2GR FOR LEV. VIEW WIN.
199	10112208	CABLE PIN TO PIN 400M 16 WAY-4 WAY

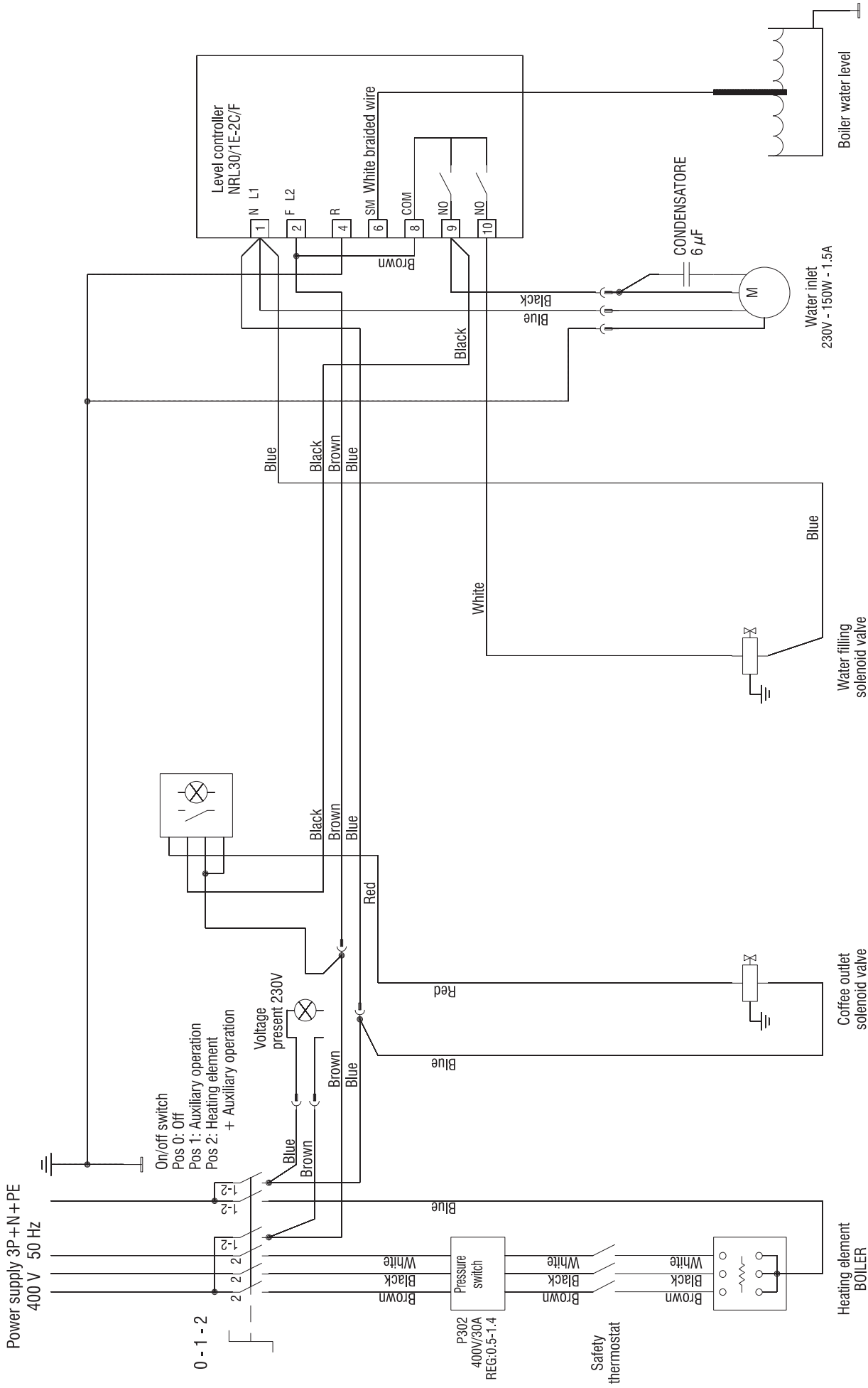

WIRING DIAGRAM CAPRI 1 GR SAP Update 09-05

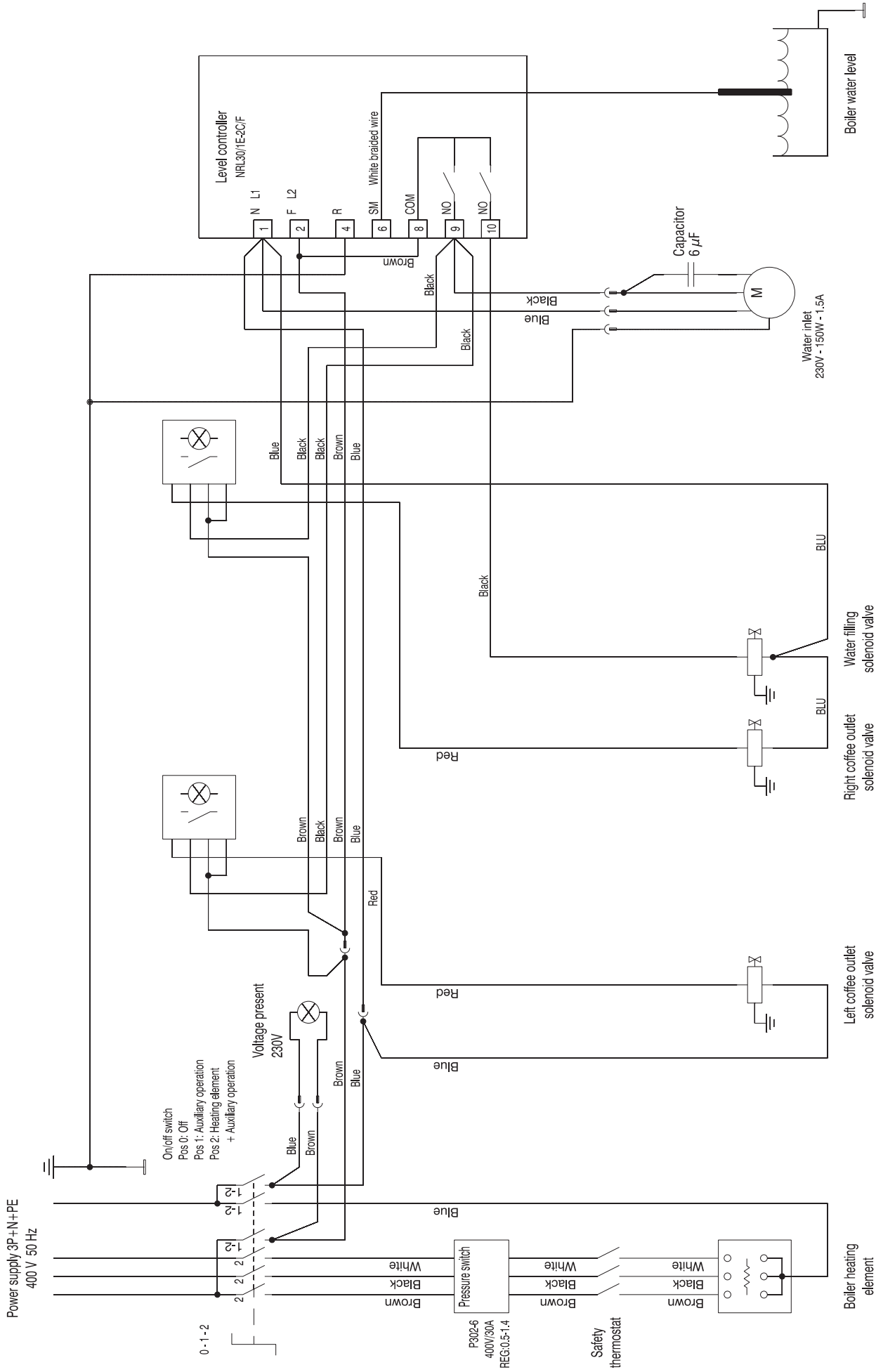

WIRING DIAGRAM CAPRI 2GR SAP Update 09-05-05

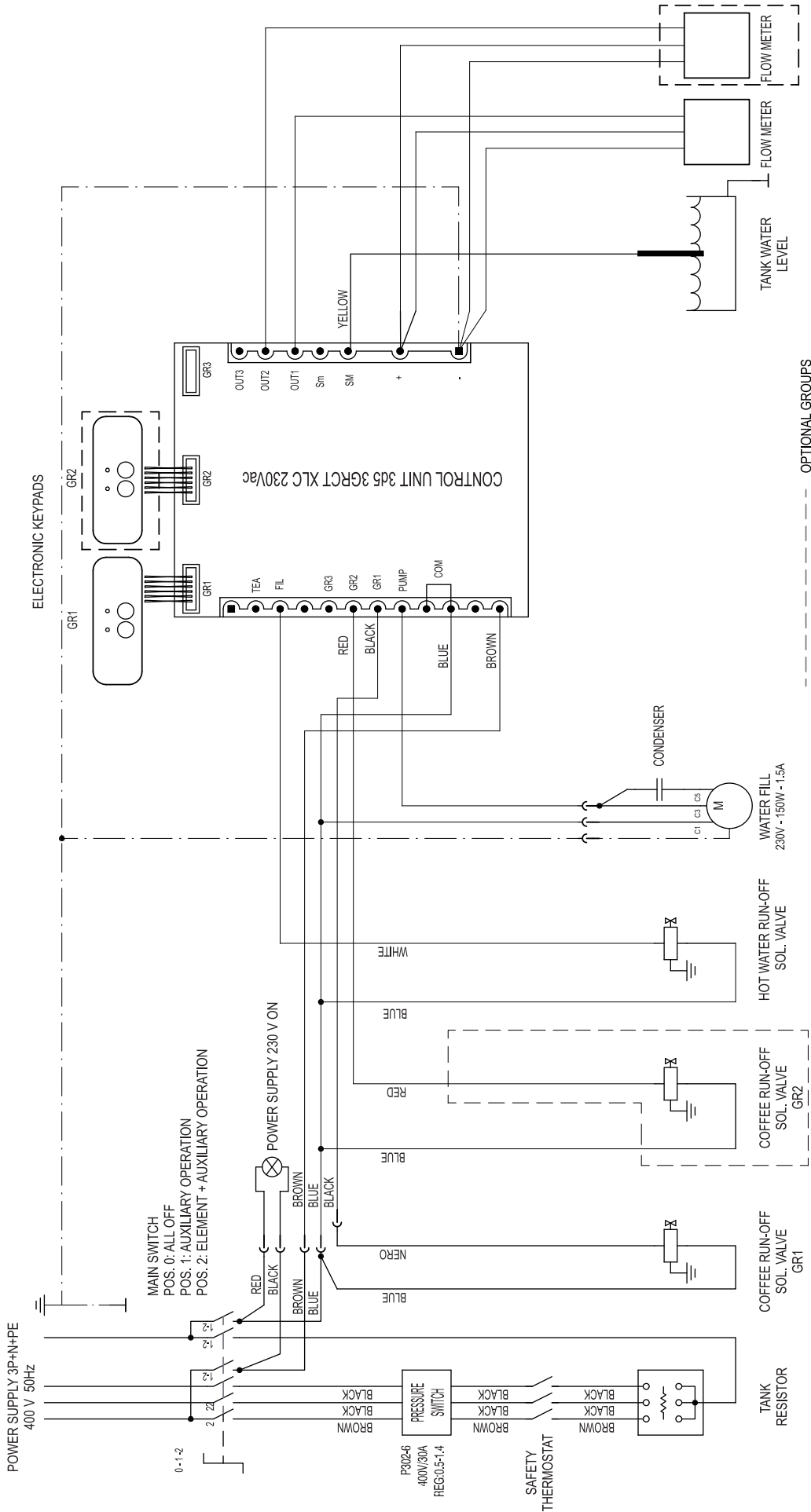

OPTIONAL GROUPS

WIRING DIAGRAM CAPRI 1-2GR SED Update 08-08

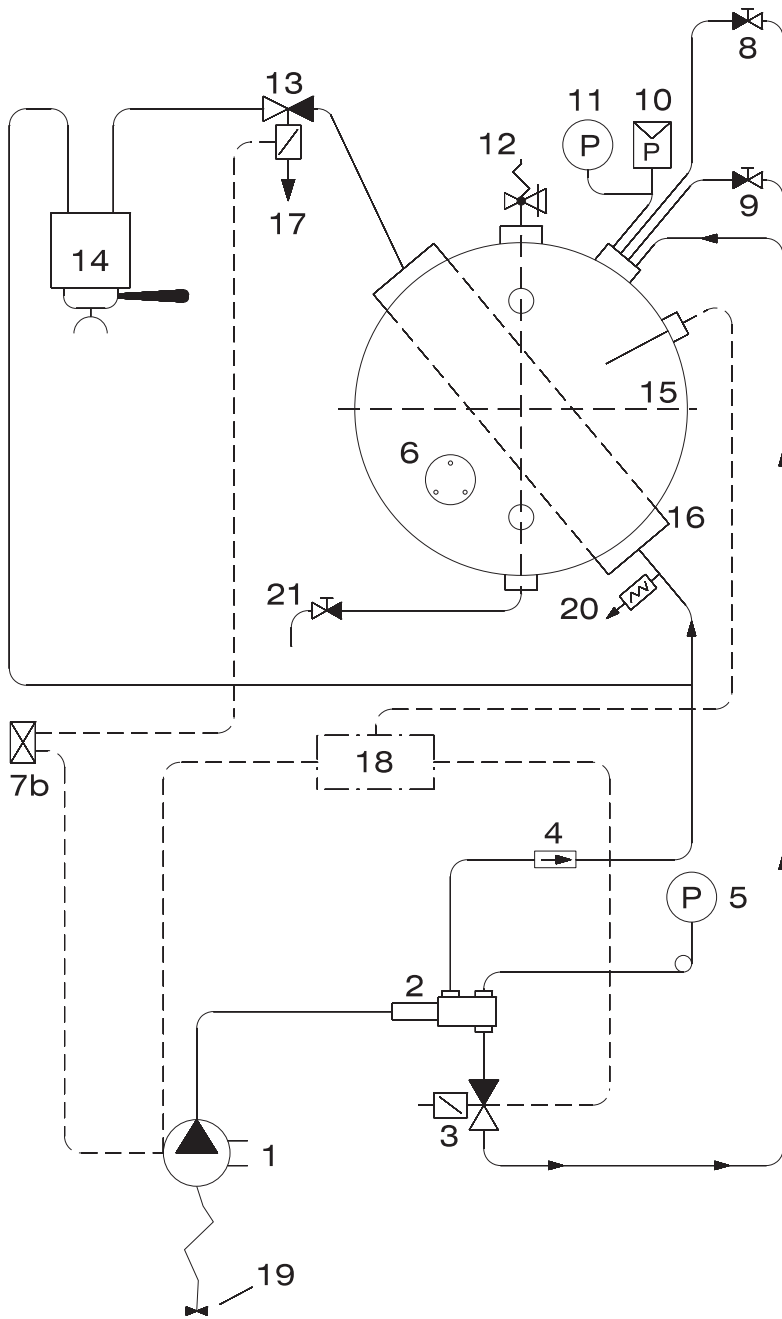

1. Feed pump
2. Water dispenser with filter
3. Solenoid valve for automatic filling
4. Check valve
5. Pump pressure gauge (scale end 16 bar)
6. Heating element
- 7b. Dispensing button
8. Hot water tap
9. Steam tap
10. Operating pressure switch
11. Boiler pressure gauge (scale end 5.5 bar)
12. Safety valve
13. Dispensing solenoid valve
14. Dispensing group head
15. Boiler
16. Exchanger
17. Dispensing valve drain
18. Level controller
19. Mains water connection
20. Expansion valve
21. Boiler drain tap

WATER CIRCUIT DIAGRAM CAPRI SAP Update 09-05

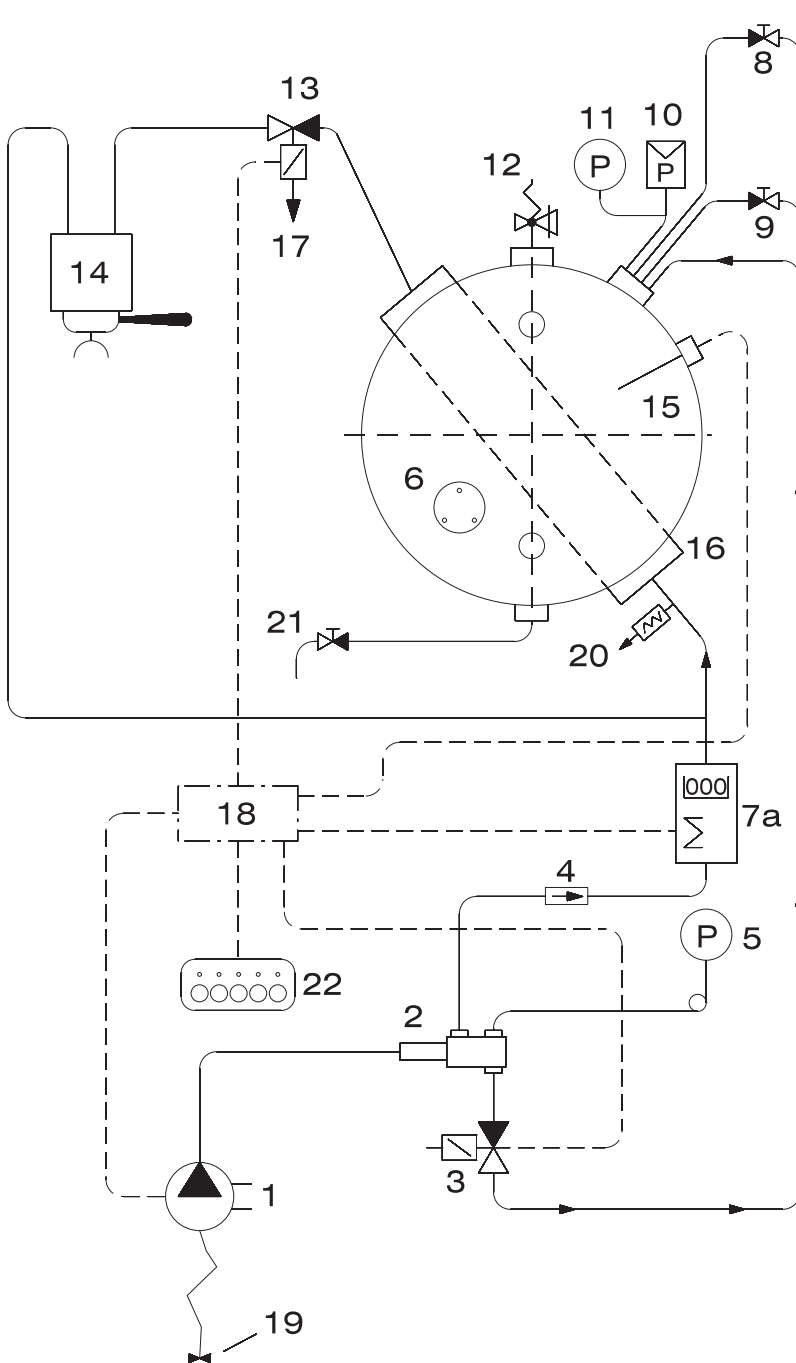

1. Feed pump
2. Water dispenser with filter
3. Solenoid valve for automatic filling
4. Check valve
5. Pump pressure gauge (scale end 16 bar)
6. Heating element
- 7a. Volumetric meter
8. Hot water tap
9. Steam tap
10. Operating pressure switch
11. Boiler pressure gauge (scale end 5.5 bar)
12. Safety valve
13. Dispensing solenoid valve
14. Dispensing group head
15. Boiler
16. Exchanger
17. Dispensing valve drain
18. Automatic dispensing control unit
19. Mains water connection
20. Expansion valve
21. Boiler drain tap
22. Keypad

WATER CIRCUIT DIAGRAM CAPRI SED Update 09-05



SANREMO PASSION / PERFORMANCE / STYLE

 **SANREMO**
MACCHINE PER CAFFÈ ESPRESSO

SANREMO s.r.l.
Via Bortolan, 52
Zona Industriale Treviso Nord
31050 Vascon di Carbonera (TV)
tel. +39 0422 448900
fax +39 0422 448935

www.sanremomachines.com